

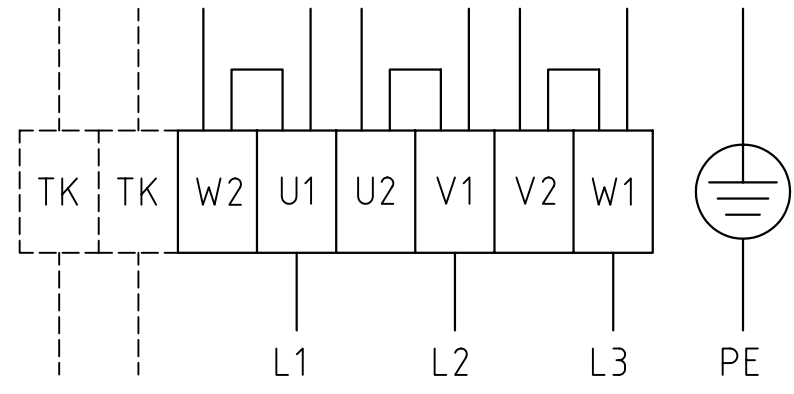

$\Delta$  3~/400V 6-POLE (900 RPM)  
 $\Delta$  3~/400V 12-POLE (450 RPM)

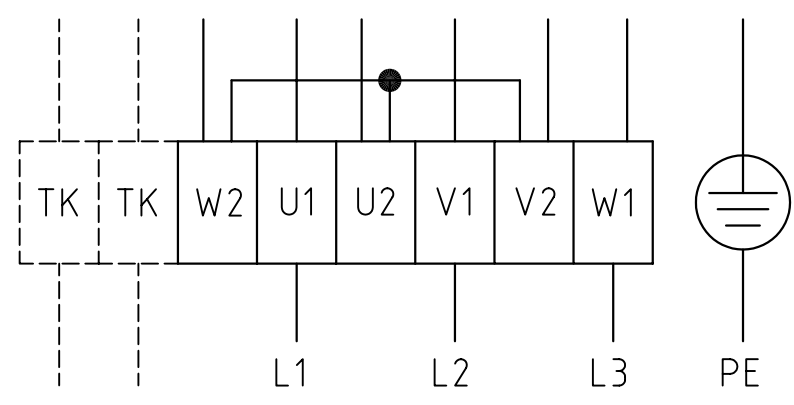

$Y$  3~/400V 6-POLE (700 RPM)  
 $Y$  3~/400V 12-POLE (300 RPM)



TK = THERMO CONTACT

05-1181 /	DET./ARTIKEL-NUMMER	MOTOR WIRING DIAGRAM $\Delta$ / $Y$		 ASARUMS INDUSTRI AB		
		XPM/CPM-80Q 3~/400V				
Denna handling är AIA:s egendom och får ej utan AIA:s skriftliga medgivande kopieras, delges tredje person eller användas för annat obehörigt ändamål	RITAD	MR	DAT.	070611	TILLHÖR RITN.	ERSÄTTER RITN.
	KONTR.		SIGN.		RITN. NR	UTG.
	GODK.		SIGN.			
			SKALA	1:1	05-1181	